

Serie 602, 604, 624 Panoramica prodotto

Caratteristiche:

- Bloccaggio ad asta di spinta versatile e compatto
- Corpo filettato per montaggio in foro passante
- Versione **-SS** in acciaio inox

Applicazioni:

- Assemblaggio
- Calibri di controllo
- Attrezzature di saldatura
- Dispositivo di tensionamento

Anche disponibili:

Consultare pag. 7.1 per gli accessori

 602
 602-**SS**
 602-**MM**
 602-**MMSS**

 604
 604-**SS**
 604-**MM**
 604-**MMSS** ⓘ

 624
 624-**SS**
 624-**MM**

Serie 602, 604, 624 Informazioni tecniche, Forze di ritegno, Dimensioni bloccaggio standard

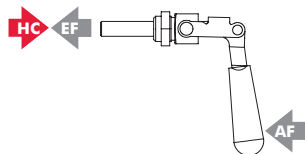

Modello	Forza di ritegno massima	Peso	EF:AF (spingendo/tirando)	Corsa dell'asta di spinta	Filettatura dell'asta di spinta (M)	Puntalino (raccomandato)	Controdado (fornito)
602					1/4-20	205203	602105
602-SS	[200 lbf] 900 N	[0.12lb] 0,05kg	31:1/28:1	[0.75] 19	M6	202943	602905
602-MM						205203-M	602105-M
602-MMSS						202943-M	602905-M
604	[300 lbf] 1330 N	[0.44lb] 0,20kg	45:1/26:1	[1.50] 38	5/16-18	207203	606104
604-SS	[400 lbf] 1780 N					--	606904
604-MM	[300 lbf] 1330 N				M8	207943	606104-M
604-MMSS ⓘ	[400 lbf] 1780 N					207943-M (fornito)	606904-M
624					3/8-16	210203	624105
624-SS	[700 lbf] 3110 N	[1.63lb] 0,74kg	49:1/21:1	[2.63] 66		237943 (fornito)	624905
624-MM					M10	210203-M	624105-M

 ⓘ Disponibile su richiesta **HC** = Forza di ritegno, **EF** = Forza di chiusura, **AF** = Forza applicata

Serie 602, 604, 624 Dimensioni bloccaggio standard
602/604/624/-SS/-MM/-MMSS

602
602-SS
602-MM
602-MMSS



604
604-SS
604-MM
604-MMSS ⓘ



624
624-SS
624-MM

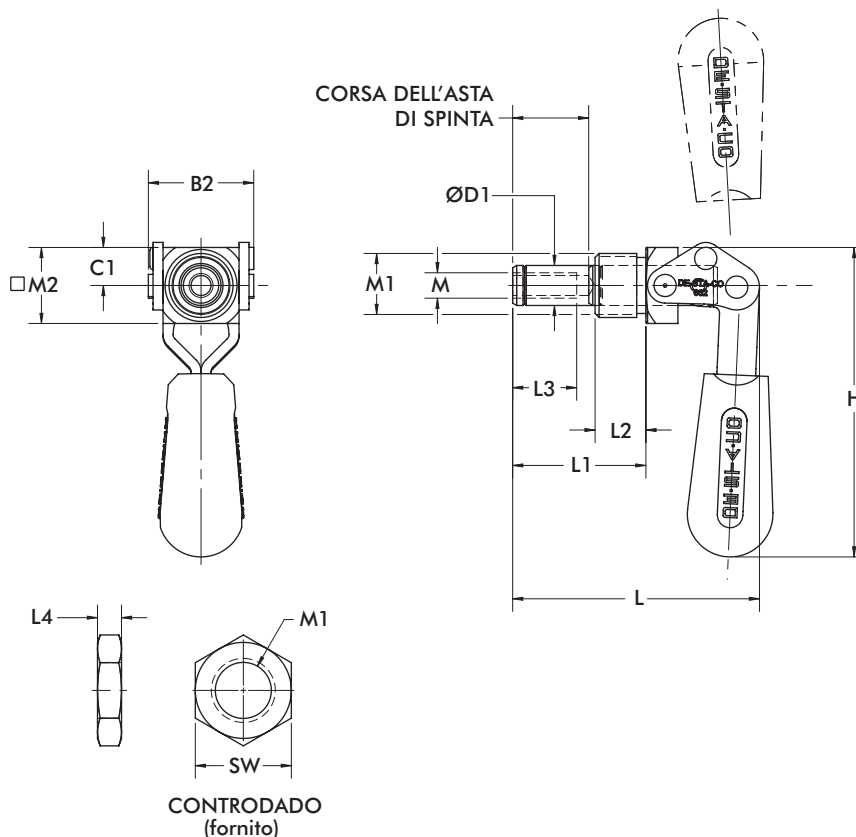

Modello no.	B2	C1	ØD1	H	L	L1	L2	L3	L4	M1	M2	SW
602			[0.39] 10									
602-SS	[1.04]	[0.37]	[0.37] 9,5	[3.13]	[2.43]	[1.31]	[0.50]	[0.63]	[0.25]	5/8-18	[0.75]	[0.88]
602-MM	26,3	9,5	[0.39]	80	61,7	33,3	12,7	16	6,4	M16x1.5	19	[0.87]
602-MMSS			10									22
604												
604-SS	[1.30]	[0.44]	[0.44]	[4.16]	[4.27]	[2.18]	[1.82]	[1.00]		3/4-16	[0.88]	[1.00]
604-MM	33	11	11	106	108,5	55	46	25		M20x1.5	22	[1.18]
604-MMSS									[0.25]			30
624												
624-SS	[1.81]	[0.75]	[0.62]	[5.60]	[6.68]	[3.62]	[3.24]	[1.25]		1-14	[1.25]	[1.50]
624-MM	46	19	16	142	170	92	82	32		M27x2	32	[1.61]
												41

Le dimensioni sono in mm [inch]

Squadrette di fissaggio per i modelli 602, 604, 624, 6004 Panoramica prodotto

Caratteristiche:

- Accessori per montare gli attrezzi ad asta di spina con corpo filettato

602106-M

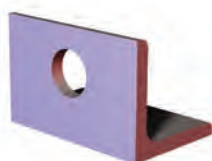

604106,
604106-M



624106-M

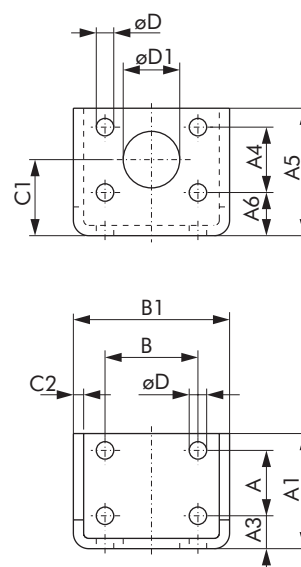
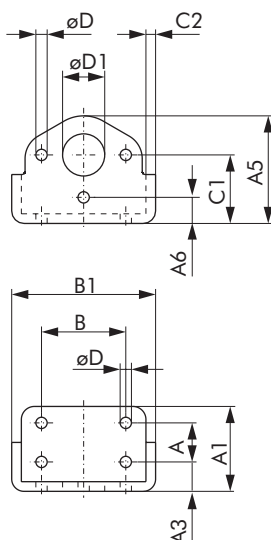
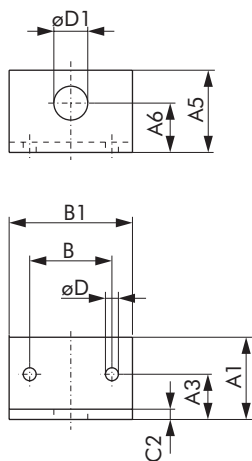

Articolo	Adatto per	A	A1	A3	A4	A5	A6	B	B1	C1	C2	D	D1
602106-M	602 602-MM	--	[1.57] 40	[0.87] 22	--	[1.57] 40	[0.94] 24	[1.57] 40	[2.36] 60	--	[0.20] 5	[0.25] 6,3	[0.65] 16,5
604106	604 6004	[0.75] 19,1	[1.60] 40,6	[0.55] 14	--	[2.05] 52,1	[0.50] 12,7	[1.62] 41,1	[2.80] 71,1	[1.30] 33	[0.19] 4,7	[0.22] 5,6	[0.75] 19,1
604106-M	604-MM 6004-MM												[0.81] 20,5
624106-M	624 624-MM	[1.25] 31,8	[2.20] 56	[0.63] 16	[1.25] 31,8	[2.44] 62	[0.83] 21	[1.78] 45,2	[2.99] 76	[1.46] 37	[0.20] 5	[0.33] 8,5	[1.08] 27,5

Le dimensioni sono in mm [inch]